

LIDDELL

CONCRETE BATCH PLANTS

RCC MOBILE MIXER



BHS Twin Shaft Batch Mixer / DKXS 4.5 – 6.0 Cubic Yard

- 6.0 cubic yards of compacted concrete output per batch (dry filling 9.0 cubic yard).
- 218 cubic yards per hour for truck mixer discharge and 301 cubic yards per hour for open truck discharge.
- (2) 100 H.P. electric motor 460 volt, 60 Hz with V-belt drive system and light weight fiberglass V-belt



937-747-4300

www.SterlingConcreteEquipment.com

RCC MOBILE MIXER

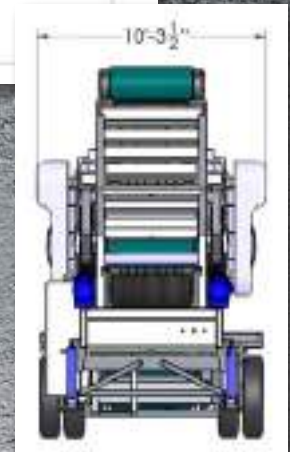
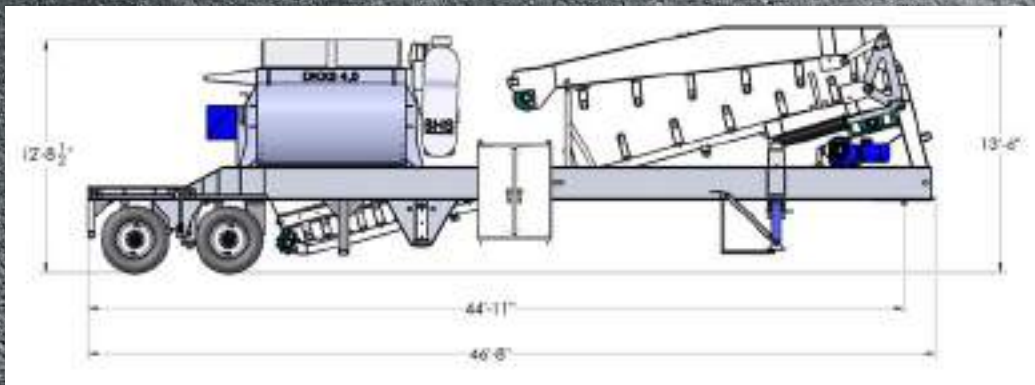
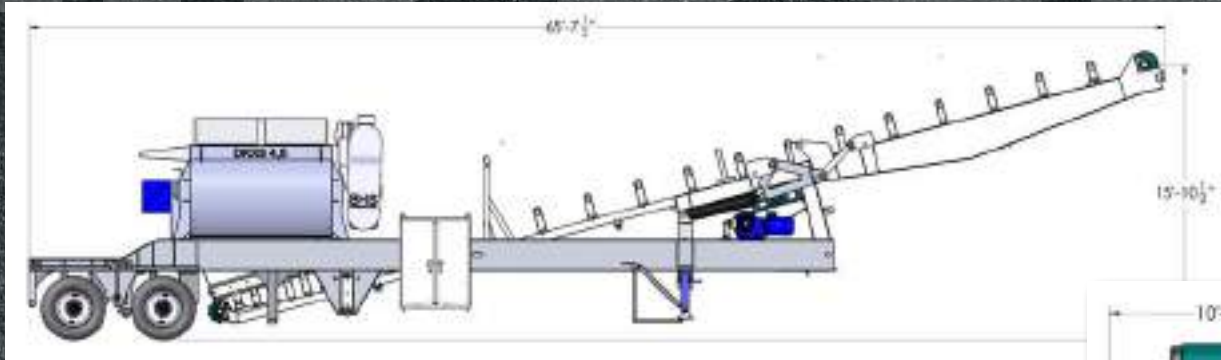

RCC MOBILE MIXER

Mobile Twin Shaft Conveyor Trailer

- Heavy Duty Structural Support Trailer / Tandem Axle
- (4) 5.5" Hydraulic Screw Jacks / Landing Gear
- (2) Manual Screw Down Jacks
- Safety / Access Decks / Mixer

Gasoline Powered Hydraulic System / Erection

- Oil Reserve
- Manual Control Package

BHS Twin Shaft Batch Mixer / DKXS 4.5 – 6.0 Cubic Yard

- Dual 100 H.P. Drive System
- Lubrication System
- Mixer Cover / Water Feeding System

42" x 55'-4" Concrete Transfer Conveyor

- Heavy Duty Channel Iron Construction
- Hinged Head Section / Travel Position
- Dual 30 H.P. Conveyor Drive Package
- 5" x 35 Degree Troughing Idlers / CEMA "C"
- 5" Return Rollers / CEMA "C"
- 4 Ply / 440 PWI Belting
- Heavy Duty Discharge Head
- Heavy Duty Polyurethane Belt Wiper
- Conveyor Safety Trip Switch

Mixer Concrete Transition Chute

Mixer / Conveyor Electrical Package

- NEMA 4 Enclosure
- Conveyor Dual 30 H.P. "Soft Start"
- Mixer Dual 100 H.P. "Soft Starts"



Manual Control Panel

- 100'-0" Control Cable

